



RE14 with wheels kit for manual handling.

TECHNICAL SPECIFICATIONS

- 1 Hopper capacity (standard): 700 litres. Conveyor belt on hopper's bottom with rollers.
- 2 Easily usable soil loading height.
- 3 Soil distribution with 3-blade rotor system (helicopter system, electronically controlled).
- 4 Double auger spillway with motorized brush for tray cleaning
- 5 Electric control panel start-stop, emergency and limit switch.
 - Available in left and right version.
- Double chain soil elevator.

TECHNICAL DATA	M.U.	RE14	RE14 A	RE14 E
HOURLY PRODUCTION (max)	trays/hour	600	600	600
HOPPER CAPACITY (standard)	l	700 (*)	700 (*)	700 (*)
TRAYS DIMENSIONS (max)	mm	600x400	750x400	750x500
TRAYS HEIGHT (max)	mm	150	150	150
INSTALLED POWER	kW	3	3	3
WEIGHT	kg	525	525	525

(*)= hopper capacity 550 liters if combined with recovery excess soil belt (ACCESSORY)

MACHINE DESCRIPTION

The RE14 tray filler returns a medium-compact soil, suitable for both seeding and transplanting. It is also suitable for all types of containers: from polystyrene to thermoformed trays as well as for pots distributed in shuttle-trays.

Thanks to the "helicopter" distribution system with electronically adjustable speed, it is possible to adjust soil density and handle even slightly humid compost, if necessary, while maintaining standard performance.

The machine is robust, simple to use and easy to maintain. Particularly suitable for production lines that require the changover of the filling material during operation: emptying of the hopper and complete cleaning of the components, in fact, are quick and simple to perform, thus saving operator time.

Thanks to the feeding belt system, the RE14 tray filler can be used both as a stand-alone machine and in a working line.

MAIN ACCESSORIES

p. 64-65

- 47
- 48
- 49
- 50
- 51
- 52
- 53
- 56
- 57
- 58
- 59

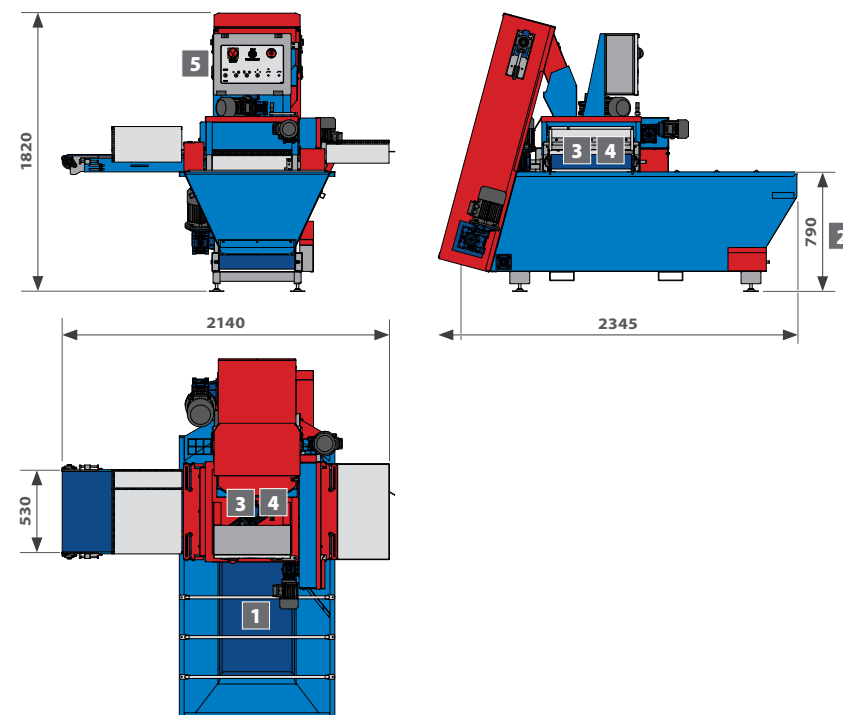

MAIN ACCESSORIES

TRAY FILLERS

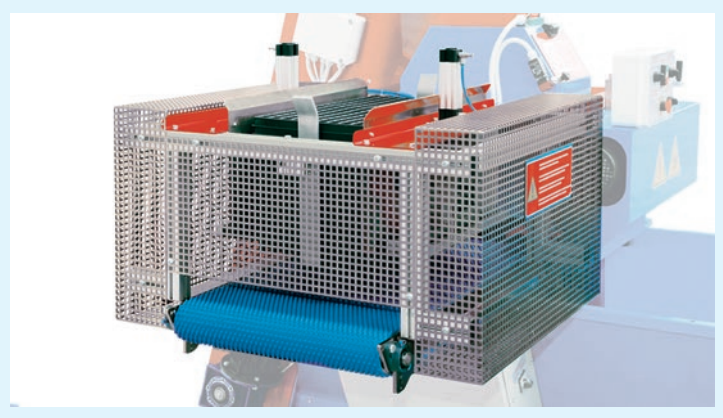

Electropneumatic **3-movements destacker**, for thermoformed trays PE - PET. **47**

AVAILABLE ON:

RN12, RT12, RE14, RC65

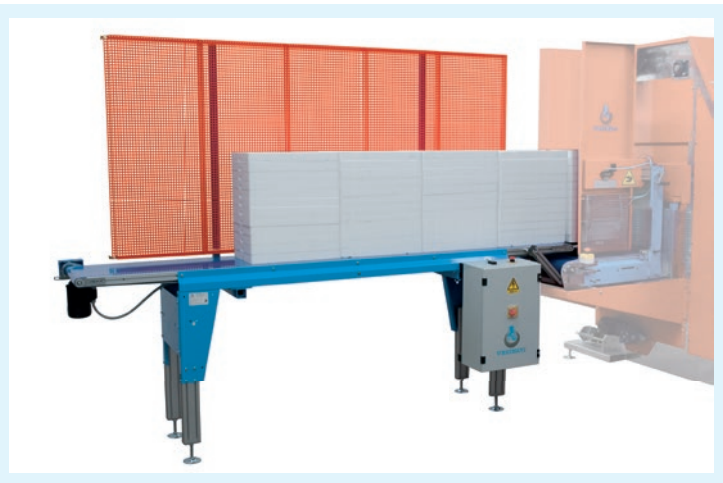

Feed belt for single trays or empty stacks for destacker
L = 3300/4300/5300/6300 mm. **50**

AVAILABLE ON:

RN12, RT12, RE14, RC65



Electropneumatic **destacker with 2-movements**, adjustable with a single crank; for polystyrene trays and trays holder. **48**

AVAILABLE ON:

RN12, RT12, RE14, RC65



Destacker for heavy plastic trays at injection in polypropylene PP. **49**

AVAILABLE ON:

RN12, RT12, RE14, RC65

- Advancement belt with electronically **adjustable speed from 200 to 800 trays/hour**.
- **Soil compactor** with rotating movement and eccentric for **adjustable density**.
- Device **for hopper emptying** with frequency driver.
- Soil hopper extension with **additional capacity of 500 liters**.

AVAILABLE ON: RT12

- **Vibrating table** on conveyor belt.

AVAILABLE ON: RN12, RT12, RE14, RC65



These are **some of the accessories available** for our **soil tray filler**.
Our **engineering dept.** is at your disposal **to suggest the best solutions** for your needs.

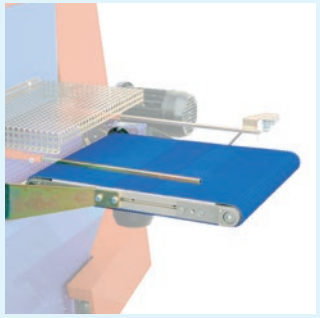

51 **Acceleration belt**
530 mm at the outlet
for the connection
to other machines.

AVAILABLE ON:
RN12, RT12, RE14, RC65

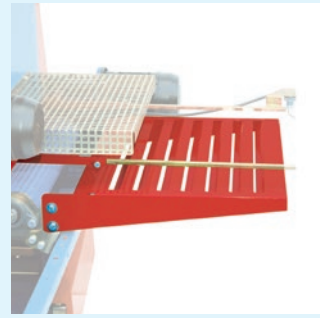

52 **Fixed table** positioned
at tray filler exit.

AVAILABLE ON:
RC65, RE14



53 **Belt system for the**
exceeding soil recycle.

AVAILABLE ON:
RC65, RE14



Quick self-centring guides adjustment system.

AVAILABLE ON:
RN12, RC65, RT12



55 **Hopper 900 liters.**

AVAILABLE ON:
RN12, RT12



56 **Hopper 1000 liters,**
complete with bulkhead
and nr. 2 turning wheels.

AVAILABLE ON:
RC65, RE14

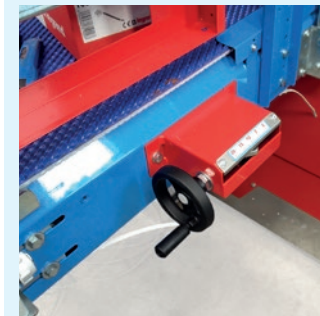

57 **Adjustment device**
for trays with legs.

AVAILABLE ON:
RN12, RC65, RE14

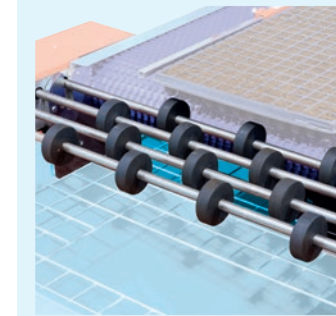

58 **Motorized exit roller,**
with nr. 4 rows.

AVAILABLE ON:
ALL TRAY FILLER



59 **Wheels kit for handling.**

AVAILABLE ON:
RC65, RE14

